

Advantages of WINMAN Linear Guideway

- Four Way Equal Load Rating
- Restrict on Quality Control
- Product are interchangeable
- Smooth Makes Less Noise
- High Parallel Accuracy of Rails and Blocks
- High Precision, High Rigidity, High Efficiency
- Lower Attitude Makes Smaller
- Low Friction Maintains Accuracy to Extend Longer Lifetime of Products

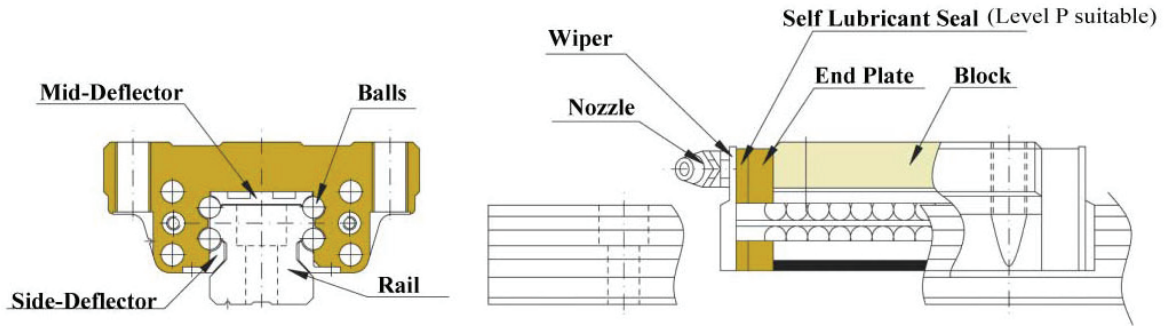

WINMAN Nomenclature

W□L25 CC 2 T 1200 II P Z1

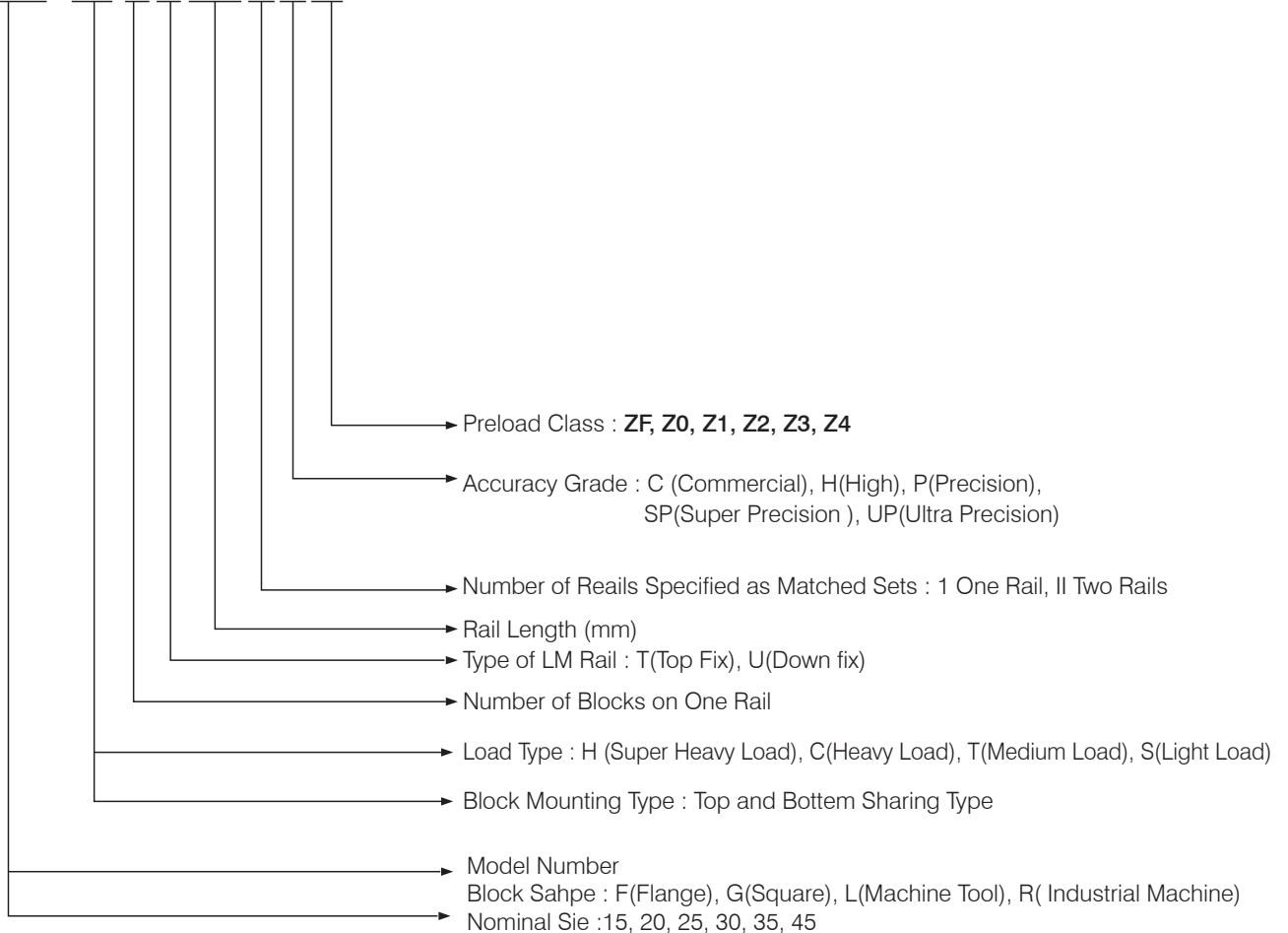

Types of WINMAN Linear Guideway

WINMAN provides machinery and industrial types, and uses either Flanges or Square models.

1. Block Shape

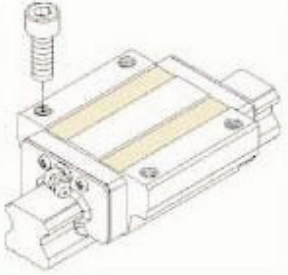
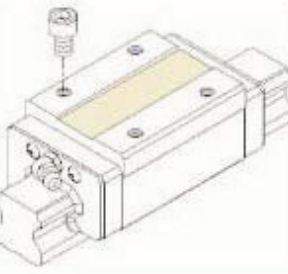
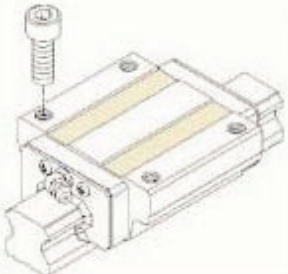
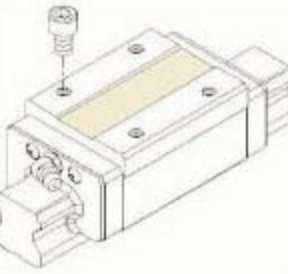
Type	Model	Shape and Direction	Height (mm)	Characteristic	Main Application
Machinery	WFL-HC WFL-CC (#15~#30)		24 } 60	<ul style="list-style-type: none"> ● Ideal Four Reway, Circular -Are Groove, Two-Point Contact Structure ● Large Permissible Load and High Rigidity can extend lifetime ● Able to be preloaded, in order to achieve high rigidity and high precision under 0 μ gap 	<ul style="list-style-type: none"> ● Machine Centers ● CNS Lathe ● Plain Grinder ● Heavy Cutting Machines ● Automation Devivces ● Measuring Equipment
	WGL-HA WGL-CA (#15~#30)		28 } 70		
Industrial	WFR-TC WFR-SC (#15~#30)		24 } 48	<ul style="list-style-type: none"> ● Smaller Compact suitable to bear load: ● Smooth Novement and Low Noise ● Standard Type: (FR-TC, GR-TA Types) Shorter Blocks, Non- Taking Space Type: (FR-SC,GR-SA Types) 	<ul style="list-style-type: none"> ● Industrial Automation Machinr ● Semineconductor Machinery ● Laser Engraving Machine ● Packaging Machine ● Transfer Equipment ● EDM
	WGR-TA WGR-SA (#15~#30)		24 } 48		

2. Rail Type

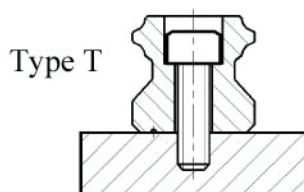

Types of WINMAN Linear Guideway

3. Preload Grade

Preload Grade	Marked	Preload	Accuracy Grade	Application
Normal Gap	ZF	Gap Value 0~0.01mm	C	Industrial Automation Machine
Non Preload	Z0	0	C~UP	Transfer Equipment, Packaging Machine
Light Preload	Z1	0.02C	C~UP	XY Axis of Ordinary Industrial Machine, Welding Machine, Fusing Machine
Medium Preload	Z2	0.05C	H~UP	Z Axis of Ordinary Industrial Machine, EDM, CNC Lathe, Percision XY Table, Measuring Equipment
Heavy Preload	Z3	0.08C	H~UP	Machine Centers, Grinding Machine, CNC Lathe, Milling Machine, Z axis of machine tools.
Ultra Heavy Preload	Z4	0.13C	H~UP	Heavy Cutting Machine

Note: The preload is the percentage of basic dynamic load rating(C)

WINMAN Mounting Proddures

1. Shoulder Angle and Height

Installing rails, you must focus on setuping up shoulder part. When shoukder angle is too big or too pver, it will make the rail less accurate or interfere the block movement. Please follow the chart below to install.

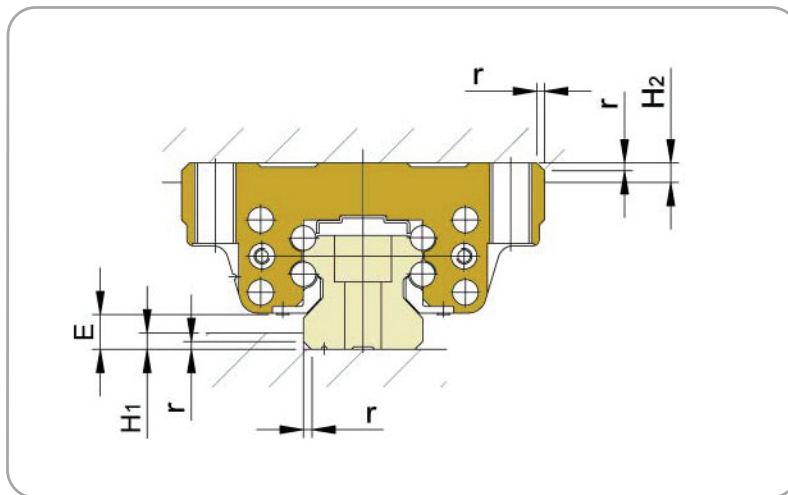

Specification	Shoulder Largest Chamfer r (mm)	Rail Shoulder Height H_1 (mm)	Block Shoulder Height H_2 (mm)	Rail Bottom Height E (mm)
15	0.3	3	4	5
20	0.3	4	5	5.5
25	0.5	5	5	7
30	0.5	5	5	8
35	0.5	6	6	9
45	1	6	6	11.5

WINMAN Mounting Procedures
2. Torsion Rate

The torsion rate of installing rails.

Specification	Screw Specification	Torsion Rate
15	M4 X 0.70P X 16L	42
20	M5 X 0.80P X 16L	90
25	M6 X 1.00P X 20L	140
30,35	M8 X 1.25P X 25L	310
45	M10 X 1.5P X 25L	690

3. Mounting rails and blocks methods

The blocks and the rails may be displaced when machine is subjected to vibrations or impacts. Suggesting to follow methods below to install. (Mounting the blocks can only imited on baseline side when usege of two parallel rails)

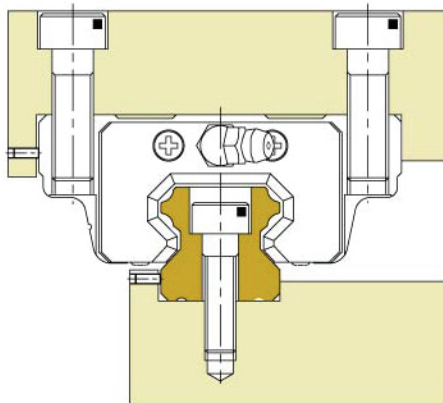
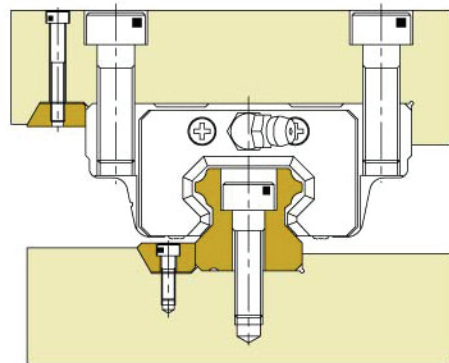
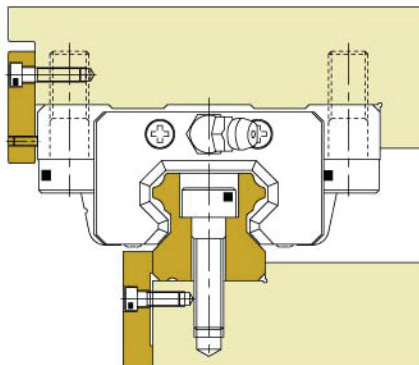
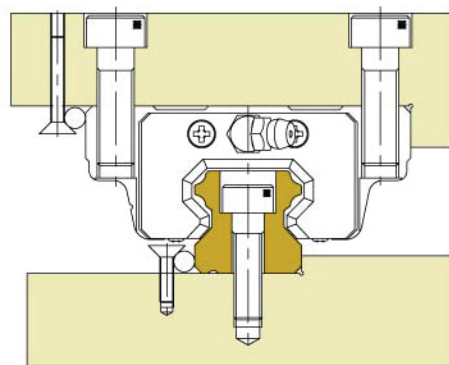
P1: Mounting with push screw

P2: Mounting with wedge briquetting

P3: Mounting with push plate

P4: Mounting with locating pin

WINMAN Choice of Accessories

1. Lubrication

It is necessary to provide effective lubrication. Using the product without lubrication may increase wear of the rolling elements or shorten the service life. Therefore, properly using lubrication can prevent rolling friction and corrosion, in order to extend lifetime.

1. Grease

- Re-lubricated every 100km
- Re-lubricated every 3-6 month
- Depending on conditions and environment to lubricate

2. Oil

- Initial Amount : Fulfilling whole space inside of blocks
- Recommending viscosity is about 30 ~150 cst to lubricate the guideway
- Supplying Oil : Q : Oil amount expectation, N: Width of rails,
- Oil feed rate is about 0.3³ cm/hr

3. Nipple Types

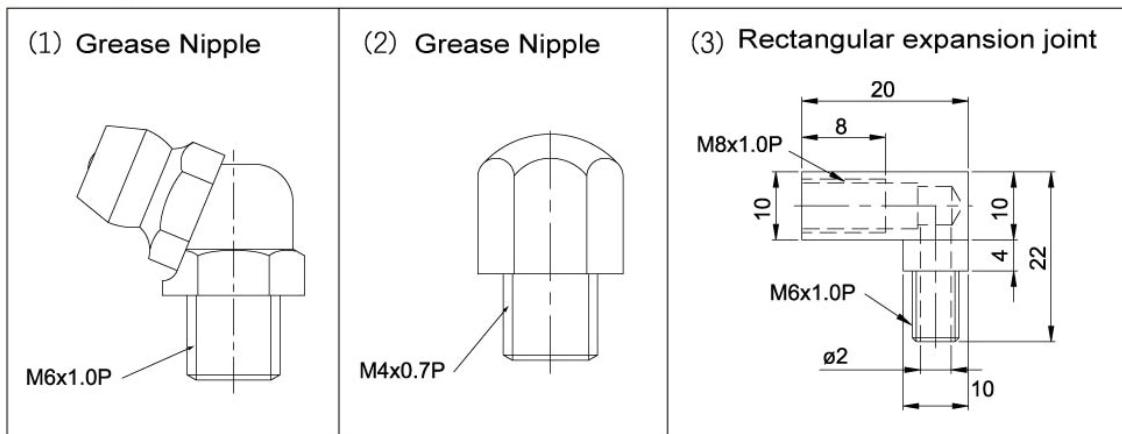

4. Manhole Covers

The cutting powder and foreign body can fill the holes on the rails. Which means, those can be inside of blocks as well. To prevent this phenomenon, WINMAN uses particular manhole covers to protect the rails.

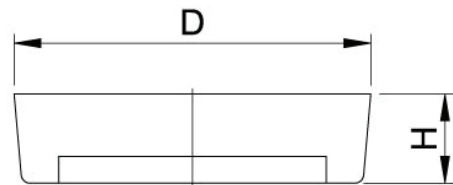

Model Type	Screw aperture	Bolts	Main Dimensions(mm)	
			D	H
15	7.5	M4	7.8	1.2
20	9.5	M5	9.8	2.2
25	11	M6	11.4	2.5
30/35	14	M8	14.4	3.4
45	20	M12	20.4	4.4

5. Guideway arrangement methods marks

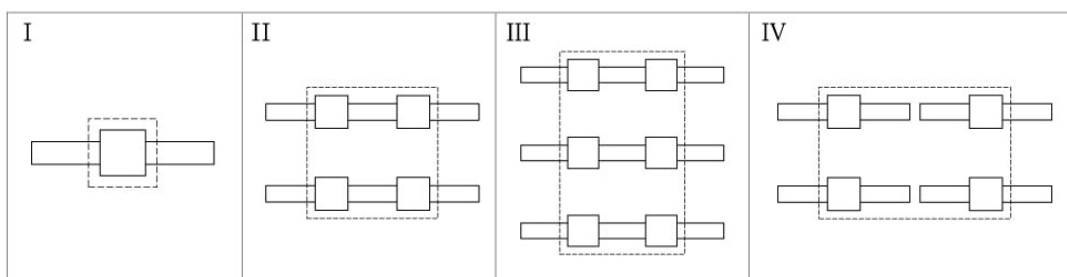

Accuracy Classification of WINMAN Linear Guideway

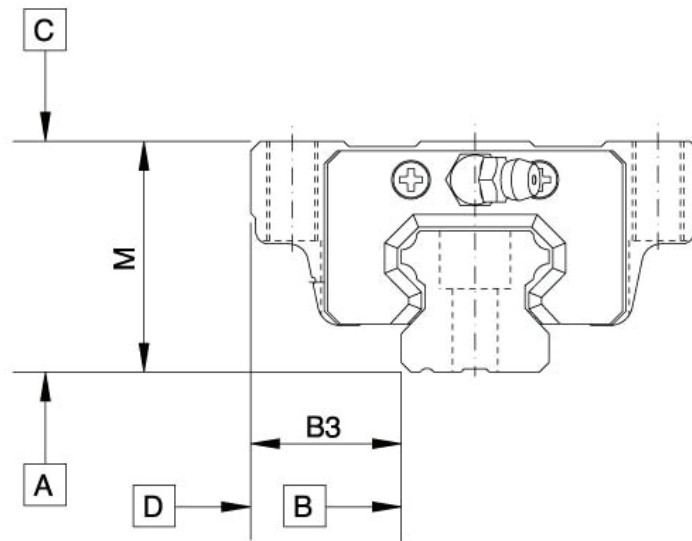

Unit (mm)		WFL / WGL / WFR / WGR-15 / 20 / 25 / 30				
Inspecting Items		Normal (C)	High (H)	Precision (P)	Super Precision (SP)	Ultra Precision (SP)
Tolerance for height M		±0.1	±0.04	$\begin{matrix} 0 \\ -0.04 \end{matrix}$	$\begin{matrix} 0 \\ -0.02 \end{matrix}$	$\begin{matrix} 0 \\ -0.01 \end{matrix}$
Tolerance for distance B3		±0.1	±0.04	$\begin{matrix} 0 \\ -0.04 \end{matrix}$	$\begin{matrix} 0 \\ -0.02 \end{matrix}$	$\begin{matrix} 0 \\ -0.01 \end{matrix}$
Differences in paris	Height M	0.02	0.015	0.007	0.005	0.003
		0.02	0.015	0.007	0.005	0.003
Preload Grade		ZF, ZO, Z1	ZO ~ Z4			
Running parallelism of surface D with surface B		See Accuracy Table of Running Parallelism Values for details				
Running parallelism of surface D with surface B		See Accuracy Table of Running Parallelism Values for details				

2. Accuracy table of Running Parallelism Values

Rail Length (mm)	Accuracy Grade (μm)				
	C	H	P	SP	UP
~100	12	7	3	2	2
100~200	14	9	4	2	2
200~300	15	10	5	3	2
300~500	17	12	6	3	2
500~700	20	13	7	4	2
700~900	22	15	8	5	3
900~1100	24	16	9	6	3
1100~1500	26	18	11	7	4
1500~1900	28	20	13	8	4
1900~2500	31	22	15	10	5
2500~3100	33	25	18	11	6
3100~3600	36	27	20	14	7
3600~4040	37	28	21	15	7

Load Rating and Service Life of Linear Guideway

Load Rating and Service Life of Linear Guideway

1. Basic Load Rating

A. Basic Static Load Rating (C₀)

If a guideway receives an excessively large load or a large impact when it is stationary or operative, permanent deformation occurs between the raceway and the rolling element. The basic static load rating (C₀) refers to a static load in a given direction with a specific magnitude applied at the contact area under the most stress where the sum of permanent deformation develops between the raceway and rolling elements is 0.0001 times of the diameter of rolling ball.

B. Basic Dynamic Load Rating (C)

The basic dynamic load rating (C) indicates the load with constant direction and magnitude under which the rated life (L) is L = 50 km for a guideway using balls, also, it used to calculate the service life.

2. Calculation of Nominal Life (L)

Without considering the conditions, the formula is shown below:

$$L = \left(\frac{C}{P} \right)^3 \cdot 50$$

L = Nominal life (km)

C = Basic dynamic load rating (N)

P = Applied load (N)

The hardness of the raceway and the temperature of the guideway unit greatly affect the service life. With these conditions considered, the practical service life calculation formulas are as follows:

$$L = \left(\frac{F_h \cdot F_t \cdot F_c}{F_w} \cdot \frac{C}{P_c} \right)^3 \cdot 50$$

L = Nominal life (km)

C = Basic dynamic load rating (N)

P_c = Applied load (N)

F_h = Hardness factor

F_t = Temperature factor

F_c = Contact factor

F_w = Load factor

1. Hardness Factor (F_h)

To maximize the load capacity of the guideway, the hardness of the raceways needs to be between 58 and 62 HRC. If the hardness is lower than this range, it will reduce load rating and lifetime of guideway.

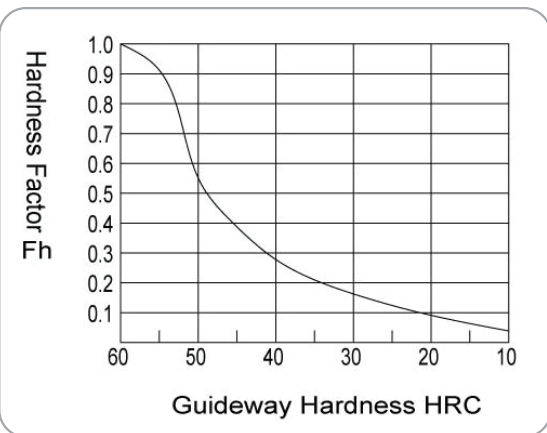

2. Contact Factor (F_c)

If multiple guide blocks are closely arranged with each other, it is difficult to achieve uniform load distribution due to a moment load and the accuracy of the mounting surface. In such applications, multiply basic load ratings "C" and "C₀" by the corresponding contact factor.

Number of blocks used in close contact	Contact factor F _c
1	1.00
2	0.81
3	0.72
4	0.66
5	0.61

Load Rating and Service Life of Linear Guideway

3. Temperature Factor (Ft)

If the temperature of the environment surrounding the operating guideway exceeds 100°C, take into account the adverse effect of the high temperature and multiply the basic load ratings by the temperature factor indicated below:

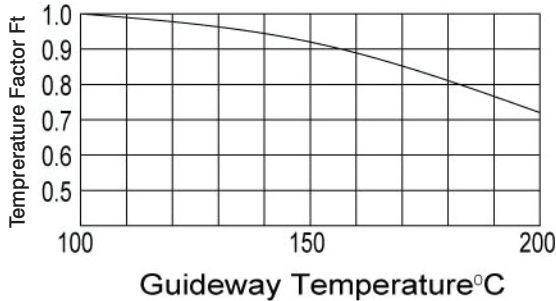

3. Applied Load

Only blocks are loaded, calculation as below:

1. Horizontal Usage

$$P = F + \frac{C_o}{M_c} (F \times L_r) + \frac{C_o}{M_a} (F \times L_p)$$

2. Transverse Usage

$$P = F + \frac{C_o}{M_c} (F \times L_r) + \frac{C_o}{M_b} (F \times L_y)$$

- P : Applied Load (N)
- F : Downward Load (N)
- C_o : Basic Static Load Rating
- M_a : Allowed Pitching torque (N.m)
- M_b : Allowed Yawing torque (N.m)
- M_c : Allowed Rolling torque (N.m)
- L_p : Distance of Pitching direction load (m)
- L_y : Distance of Yawing direction load (m)
- L_r : Distance of Rolling direction load (m)

4. Load Factor (Fw)

If it is extremely difficult to accurately determine vibrations generated during high-speed operation and impact during frequent start and stop. Therefore, where the effects of speed and vibration are estimated to be significant, use the load factor indicated below:

Vibrations/Impact	Speed (V)	Fw
Faint	V ≤ 15m/min	1~1.5
Medium	15 < V ≤ 60m/min	1.5~2.0
Strong	V > 60m/min	2.0~3.5

4. Calculation of the Mean Load

When a linear guideway system receives varying loads, the service life could be calculated in consideration of varying loads of the host-system operation conditions. Calculation of Mean loads below:

$$P_m = \sqrt[3]{\frac{1}{L} \cdot \sum_{n=1}^n (P_n^3 \cdot L_n)}$$

- P_m : Mean load (kgf)
- P_n : Varying load (kgf)
- L : Total running distance (mm)
- L_n : Running distance under load P_n (mm)

5. Calculation of the Equivalent Load

The linear guideway system can take up loads moments in all four directions those are radial load, reverse-radial load, and lateral load simultaneously. Calculating formula as below:

$$P_e = P_r + P_t$$

- P_e = Equivalent load (kgf)
- P_r = Radial or reverse-radial load (kgf)
- P_t = Transverse Load (kgf)

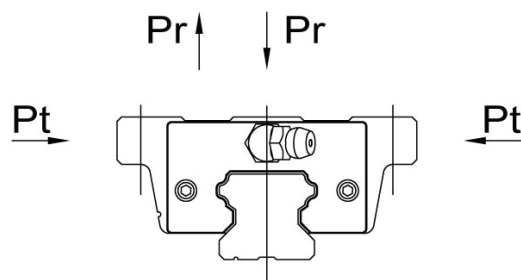

FLANGE MODEL WFL-CC, WFL-HC

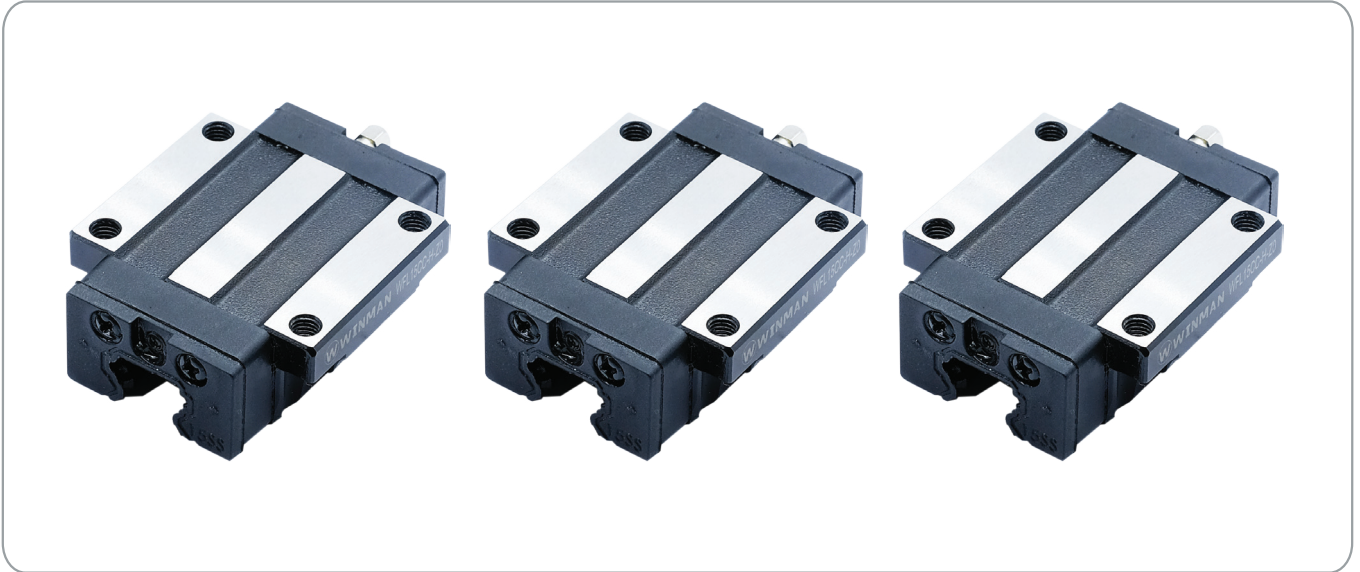

WINMAN Block Dimensions /mm

Model	Width (W)	Length (L)	Height (H)	B	B1	L1	C	T	T1	T2	SxI	N	E	Grease Fitting
WFL15CC	47	59.2	24	38	4.5	38.2	30	7	11	19.5	M5x7	4.5	7	M4x0.7P
WFL20CC	63	76.5	30	53	5	50.5	40	9.5	10	24.5	M6x9.5	5	12	M6x1.0P
WFL20HC	63	92.5	30	53	5	66.5	40	9.5	10	24.5	M6x9.5	5	12	M6x1.0P
WFL25CC	70	84	36	57	6.5	58	45	12	16	29.0	M8x12	6	12	M6x1.0P
WFL25HC	70	103	36	57	6.5	77	45	12	16	29.0	M8x12	6	12	M6x1.0P
WFL30CC	90	100.5	42	72	9	70.5	52	12	18	34.0	M10x12	7	12	M6x1.0P
WFL30HC	90	122.5	42	72	9	92.5	52	12	18	34.0	M10x12	7	12	M6x1.0P
WFL35CC	100	105.5	48	82	9	80.5	62	13	21	39.0	M10x13	8	12	M6x1P
WFL45CC	120	128.2	60	100	10	99.2	80	14	25	48.5	M12 x14	10	16	1/8 PT

FLANGE MODEL WFL-CC, WFL-HC

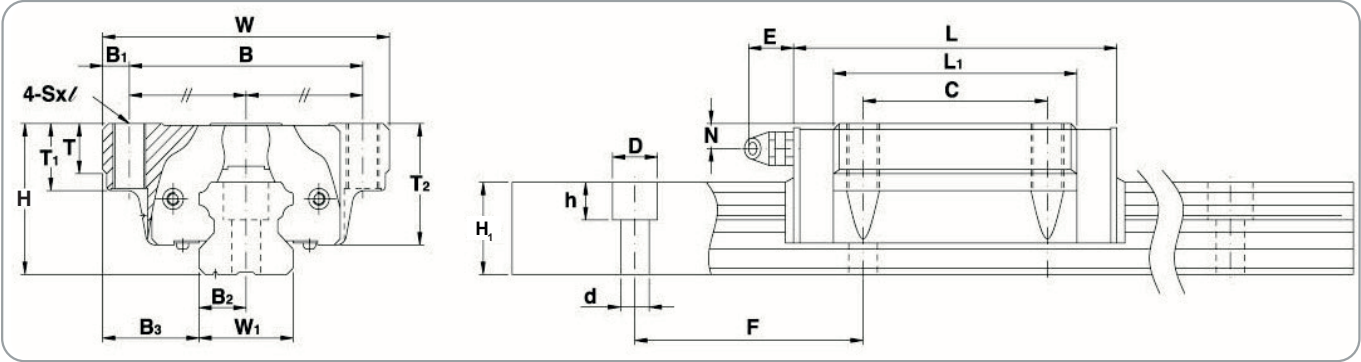

WINMAN Rail Dimensions /mm

Genişlik (W)	Yükseklik (H)	Mesafe (F)	B ₂	B ₃	dxDxh	C kgf	C ₀ kgf	MA kgf-M	MB kgf-M	Mc kgf-M	Araba kg/adet	Ray kg/ m
15	15	60	7.5	16	4.7x7.5x5.5	850	1380	7.3	7.3	10.1	0.2	1.7
20	18	60	10	21.5	6x9.5x8.5	1410	2430	15.9	15.9	23.7	0.35	2.5
20	18	60	10	21.5	6x9.5x8.5	2170	3240	27.5	27.5	31.6	0.7	2.5
23	22	60	11.5	23.5	7x11x9	2030	3510	27.5	27.5	40.0	0.59	3.6
23	22	60	11.5	23.5	7x11x9	2770	4680	46.8	46.8	51.8	0.75	3.6
28	26	80	14	31	9x14x12	2860	4770	43.8	43.8	65.8	1.1	5.1
28	26	80	14	31	9x14x12	3800	6370	74.4	74.4	87.7	1.3	5.1
34	29	80	17	33	9x14x12	3800	6230	65.4	65.4	104.7	1.6	
45	38	105	22.5	37.5	14x20x17	6120	9750	127.6	127.6	213.2	2.8	

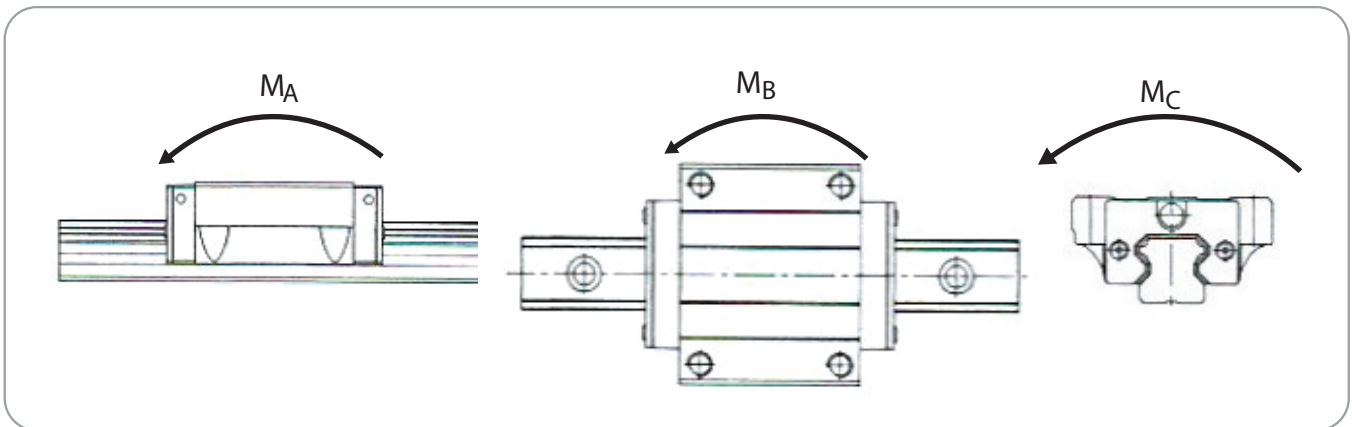

SQUARE MODEL WGL-CA,HA

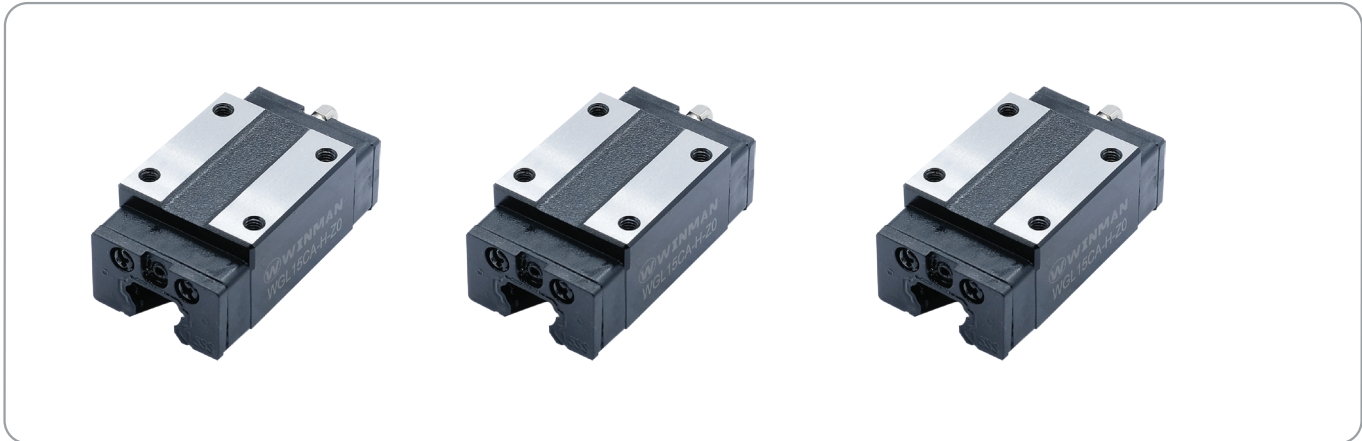

Model	Width (W)	Lenght (L)	Height (H)	B	B1	L1	C	T	T2	SxI	N	E	Grease Fitting
WGL15CA	34	56.2	28	26	4	38.2	26	6	23.5	M4x5	8.5	7	M6x1.0P
WGL20CA	44	76.5	30	32	6	50.5	36	8	24.5	M5x6	10	12	M6x1.0P
WGL20HA	44	92.5	30	32	6	66.5	50	8	24.5	M5x6	10	12	M6x1.0P
WGL25CA	48	84	40	35	6.5	58	35	12	33.0	M6x8	10	12	M6x1.0P
WGL25HA	48	103	40	35	6.5	77	50	12	33.0	M6x8	10	12	M6x1.0P
WGL30CA	60	100.5	45	40	10	70.5	40	12	37.0	M8x10	10	12	M6x1.0P
WGL30HA	60	122.5	45	40	10	92.5	60	12	37.0	M8x10	10	12	M6x1.0P
WGL35CA	70	105.5	55	50	10	80.5	50	12	46	M8x12	15	12	M6x1.0P
WGL35HA	70	130.5	55	50	10	105.5	72	12	46	M8x12	15	12	M6x1.0P
WGL45CA	86	128.2	70	60	13	99.2	60	15	58.5	M10x17	20	16	1/8PT
WGL45HA	86	159.5	70	60	13	130.5	80	15	68.5	M10x17	20	16	1/8PT

SQUARE MODEL WGL-CA,HA

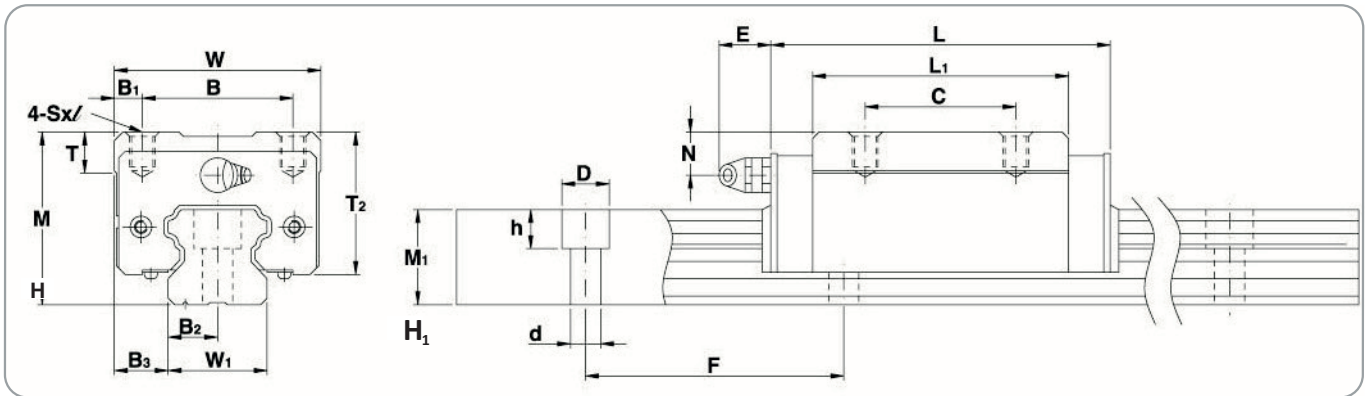

WINMAN Rail Dimensions /mm

Width (W ₁)	Lenght (H ₁)	Pitch (F)	B ₂	B ₃	dxDxh	C kgf	C ₀ kgf	M _A kgf-M	M _B kgf-M	M _C kgf-M	Block kg/Piece	Rail kg/M
15	15	60	7.5	9.5	4.7x7.5x5.5	850	1380	7.3	7.3	10.1	0.18	1.7
20	18	60	10	12	6x9.5x8.5	1410	2430	15.9	15.9	23.7	0.25	2.5
20	18	60	10	12	6x9.5x8.5	2170	3240	27.5	27.5	31.6	0.35	2.5
23	22	60	11.5	12.5	7x11x9	2030	3510	27.5	27.5	40.0	0.54	3.6
23	22	60	11.5	12.5	7x11x9	2770	4680	46.8	46.8	51.8	0.67	3.6
28	26	80	14	16	9x14x12	2860	4770	43.8	43.8	65.8	0.9	5.1
28	26	80	14	16	9x14x12	3800	6370	74.4	74.4	87.7	1.1	5.1
34	29	80	17	18	9x14x12	3800	6230	65.4	65.4	104.7	1.6	6.9
34	29	80	17	18	9x14x12	5120	8310	111.1	111.1	139.9	2.0	6.9
45	38	105	22.5	20.5	14x20x17	6120	9750	127.6	127.6	213.2	2.6	11.0
45	38	105	22.5	20.5	14x20x17	8200	13000	217.1	217.1	284.1	3.1	11.0

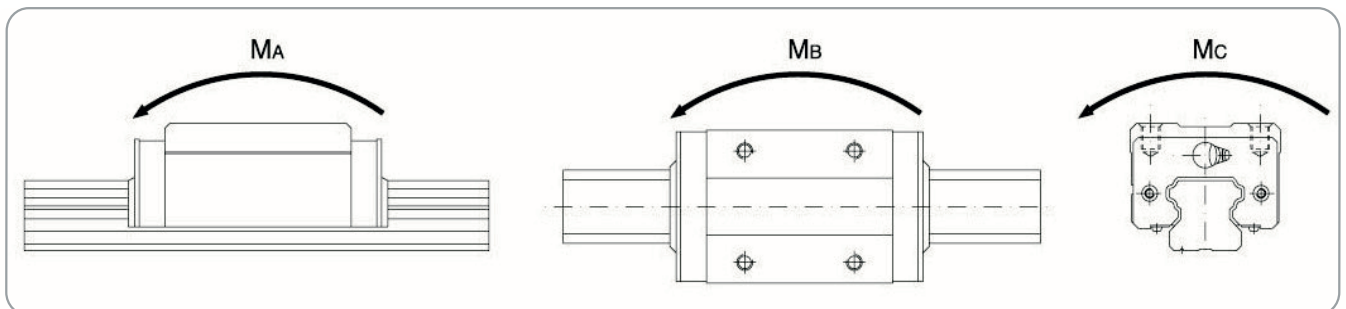

FLANGE MODEL WFR-TC,SC



Model	Width (W)	Length (L)	Pitch (H)	B	B1	L1	C	T	T1	T2	SxI	N	E	Grease Fitting
WFR15TC	52	56.2	24	41	5.5	38.2	26	7	11	19.5	M5x7	4	7	M4x0.7P
WFR15SC	52	39.3	24	41	5.5	21.3	-	7	11	19.5	M5x7	4	7	M4x0.7P
WFR20TC	59	67.2	28	49	5	47.2	32	9.5	10	22	M6x9.5	4	12	M6x1.0P
WFR20SC	59	47.5	28	49	5	27.5	-	9.5	10	22	M6x9.5	4	12	M6x1.0P

FLANGE MODEL WFR-TV,SC

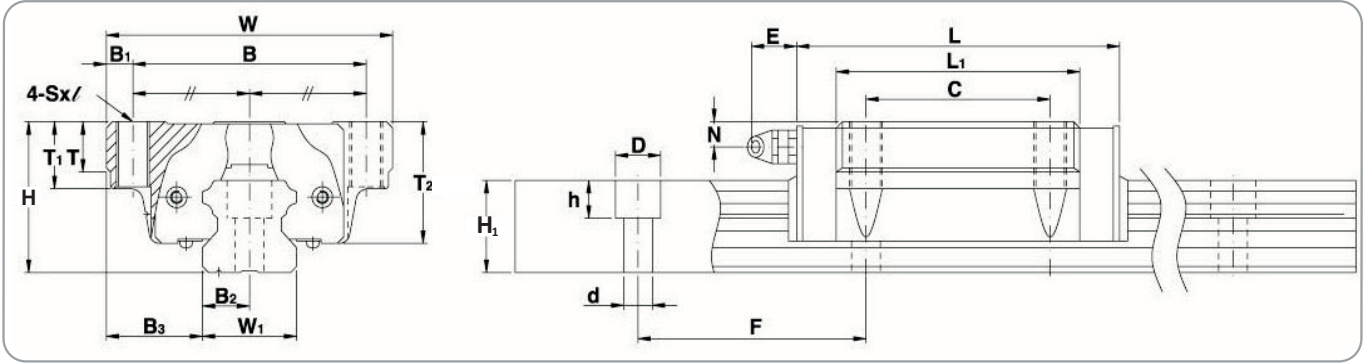

Width W ₁	Lenght H ₁	Pitch (F)	H ₁	B ₃	dxDx	C kgf	C ₀ kgf	MA kgf-M	MB kgf-M	Mc kgf-M	Block kg/adet	Rail kg/m
15	15	60	7.5	18.5	4.7x7.5x5.5	850	1380	7.3	7.3	10.1	0.2	1.7
15	15	60	7.5	18.5	4.7x7.5x5.5	850	1132	2.04	2.04	4.08	0.15	1.7
20	18	60	10	19.5	6x9.5x8.5	1410	2430	15.9	15.9	23.7	0.42	2.5
20	18	60	10	19.5	6x9.5x8.5	730	1468	3.06	2.04	7.14	0.35	2.5

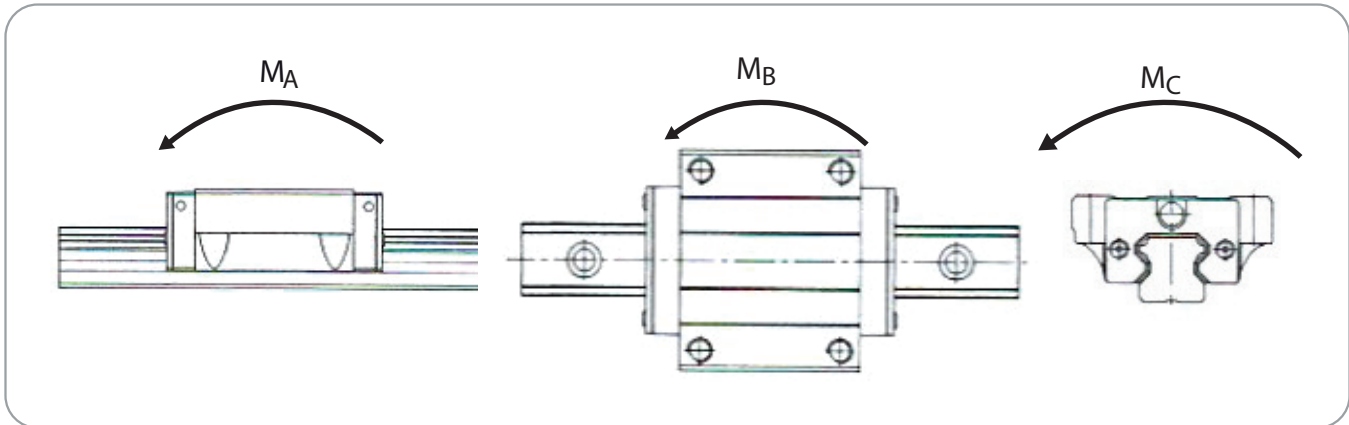

SQUARE MODEL WGR-TA,SA

Model	Width (W)	Length (L)	Height (H)	B	B ₁	L ₁	C	T	T ₂	SxI	N	E	Grease Fitting
WGR15TA	34	56.2	24	26	4	38.2	26	6	19.5	M4x5	4	7	M4x0.7P
WGR15SA	34	39.5	24	26	4	21.3	-	6	19.5	M4x5	4	7	M4x0.7P
WGR20TA	42	67.2	28	32	5	47.2	32	7.5	22	M5x6	4	12	M6x1.0P
WGR20SA	42	47.5	28	32	5	27.5	-	7.5	22	M5x6	4	12	M6x1.0P
WGR25TA	48	79.5	33	35	6.5	59.5	35	8	26	M6x8	4.5	12	M6x1.0P
WGR25SA	48	55.0	33	35	6.5	35.0	-	8	26	M6x8	4.5	12	M6x1.0P

SQUARE MODEL WGR-TA,SA

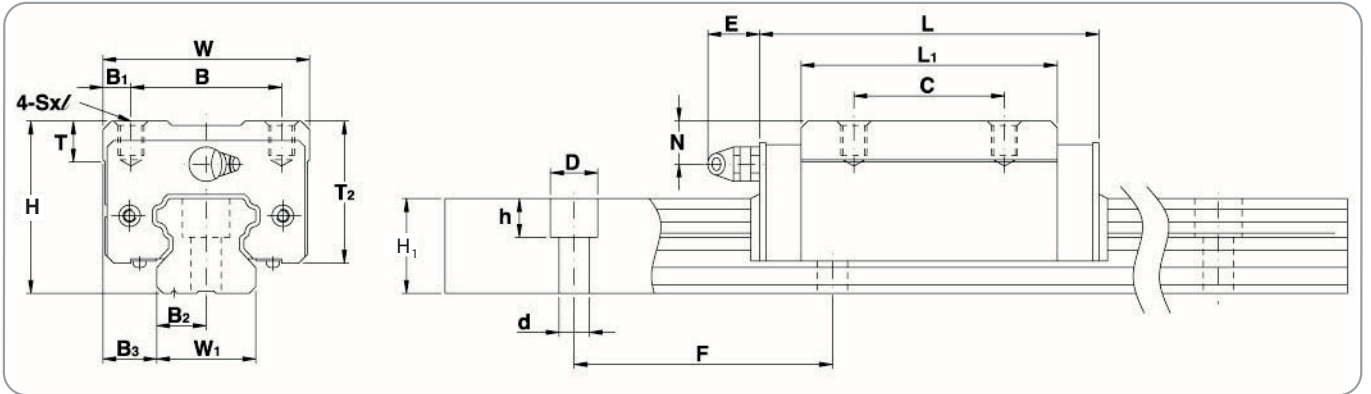

WINMAN Rail Dimensions/mm

Width W	Height H	Pitch (F)	B ₂	B ₃	dxDx	C kgf	C ₀ kgf	MA kgf-M	MB kgf-M	Mc kgf-M	Block kg/Piece	Rail kg/M
15	15	60	7.5	9.5	4.7x7.5x5.5	850	1380	7.3	7.3	10.1	0.18	1.7
15	15	60	7.5	9.5	4.7x7.5x5.5	550	1132	2.04	2.04	4.08	0.11	1.7
20	18	60	10	11	6x9.5x8.5	1410	2430	15.9	15.9	23.7	0.25	2.5
20	18	60	10	11	6x9.5x8.5	730	1468	3.06	2.04	7.14	0.23	2.5
23	22	60	11.5	12.5	7x11x9	2030	3510	27.5	27.5	40.0	0.54	3.6
23	22	60	11.5	12.5	7x11x9	1190	2295	5.1	4.08	12.24	0.45	3.6

