

VNR-C-34-100-...

RÜCKSCHLAGVENTIL/CARTRIDGE CHECK VALVE

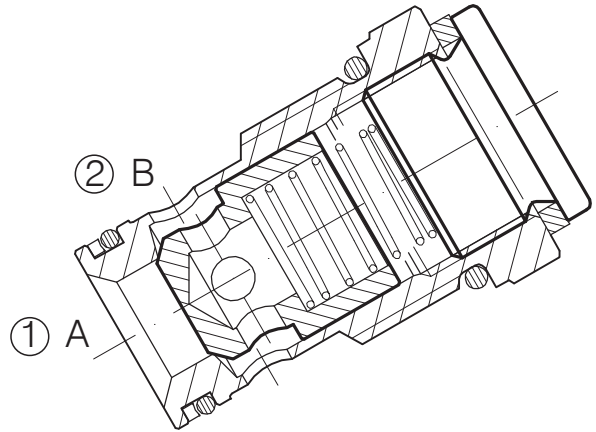
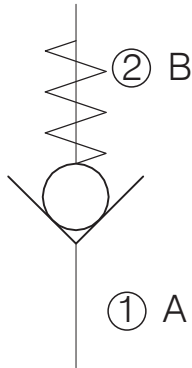

Leistung/Performance

Bewertet grÖÙe/Rated size	DN 16
Max Arbeitsdruck/ Min/Max flow-rate	1/150 l/min - 0.26/39.6 GPM
Min / Max-Durchfluss/Max working pressure	350 bar - 5075 PSI
Zimmertemperatur/ Room temperature	-30°C + 50°C
Öltemperatur/Oil temperature	-30°C + 80°C
Empfohlene Filtration/Recommended filtration	50 micron
Anzugsdrehmoment/Tightening torque	148÷158 Nm
Gewicht/Weight	0.292 Kg

Leistungsdetails/Performance Details

