

WS1 Square swivel & clamp cylinders
Features

1. The tube body is square which has the same dimensions of the JUFAN made compact cylinder ("JIG" series).
2. This square type cylinder is most powerful one in the "WS" series.
3. Sensing proximity can be applied onto this WS1 cylinders.

Theoretical force

Bore (mm)	Rod (mm)	Pressed area (cm ²)	Clamping force(kgf)							
			Working pressure (kgf/cm ²)							
			2	3	4	5	6	7	8	9
Ø 20	10	2.3	4.6	6.9	9.2	11.5	13.8	16.1	18.4	20.7
Ø 25	10	4.0	8	12	16	20	24	28	32	36
Ø 32	12	6.9	13.8	20.7	27.6	34.5	41.4	48.3	55.2	62.1
Ø 40	16	10.5	21	31.5	42	52.5	63	73.5	84	94.5
Ø 50	20	16.5	33	49.5	66	82.5	99	115.5	132	148.5
Ø 63	20	28	56	84	112	140	168	196	224	252

Specifications

Bore (mm)	Ø 20, Ø 25	Ø 32, Ø 40	Ø 50, Ø 63
Acting	Double acting		
Swivel angel	90° / 180° ±2°		
Swivel direction	Left or right		
Swivel stroke (mm)	9.5	15	20
Clamp stroke (mm)	20		
Fluid	Air		
Working pressure	<=9.9kgf/cm ²		
Test pressure	15kgf/cm ²		

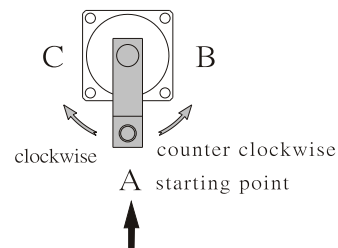

L:left swivel at counter-clockwise direction :
 A:staring point B:end point
 R:right swivel at clockwise direction :
 A:staring point C:end point

WS1 Swivel & Clamp Pneumatic Cylinders

Standard

Unit : mm

Bore	20	25	32	40	50	63
Swivel						
90° left	●	●	●	●	●	●
90° right	●	●	●	●	●	●
180°	as request					

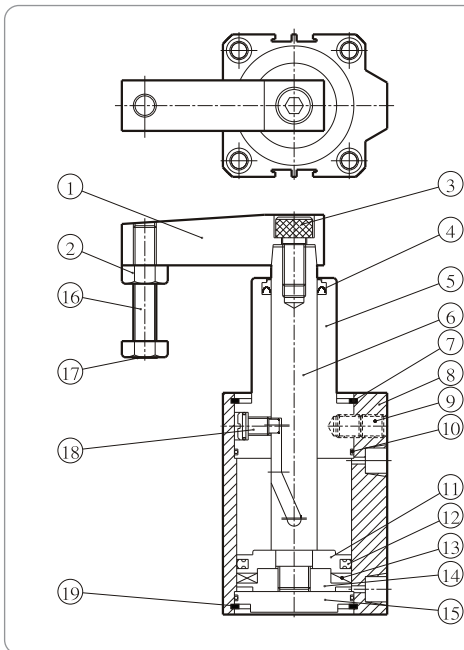
Structure and parts list

Item	Part name	Qty
1	plate	1
2	hex. nut	1
3	hex. bolt	1
4	Rod seal	1
5	Rod cover	1
6	Rod	1
7	c snap ring	1
8	body	1
9	hex. set screw	2
10	o-ring	2
11	Front piston	1
12	Piston packing	1
13	Magnet	1
14	Real piston	1
15	Head cover	1
16	plat bolt	1
17	press nut	1
18	pilot pin	1
19	c snap ring	1

Seal specifications

Bore	Item	④ Rod seal		⑫ Piston packing		⑩ o-ring	
		Item	Qty	Item	Qty	Item	Qty
20		PDU10	1	APA20	1	SM22(rod)	2
						SM20(head)	1
25		PDU10	1	APA25	1	SM25	3
32		PDU12	1	APA32	1	SM30	2
40		PDU16	1	APA40	1	SM38	2
50		PDU20	1	APA50	1	SM46	2
63		PDU20	1	APA63	1	SM60	2

WS1 Swivel & Clamp Pneumatic Cylinders

Structure

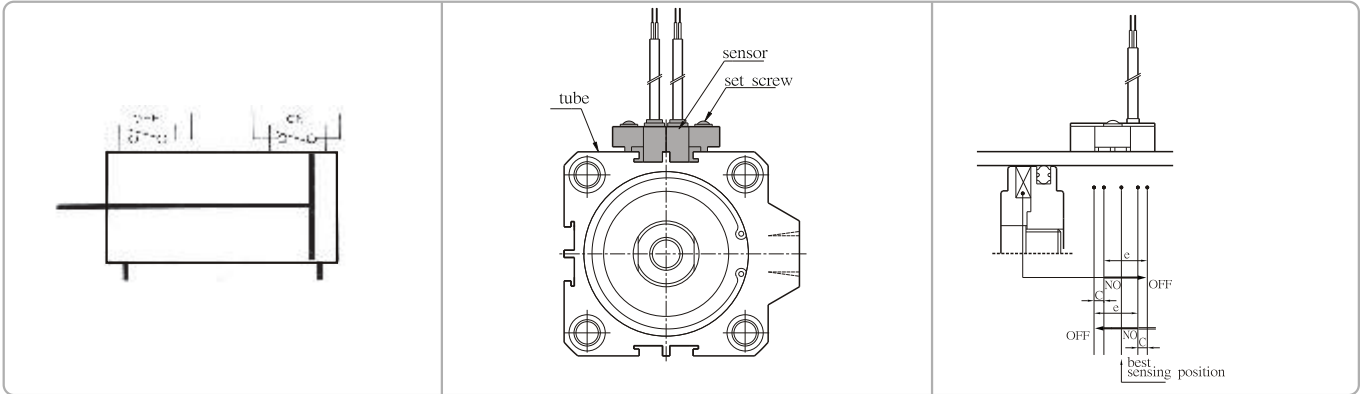

■ Features and circuit diagrams can be referred at P14.3~P14.4

Order Form

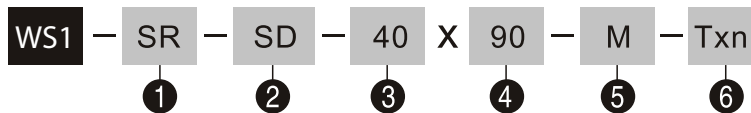

WS1:WS1 Square swivel & clamp cylinders

1	(1)SR=Single side,Right swivel (2)DR=Doublesides,Right swivel (3)SL=Single side,Left swivel (4)DL=Double sides, Left swivel
2	Mounting type : (1)SD : Standard (2)FB : flage
3	Bore(mm):20,25,32,40,50,63
4	swivel : 90° , 180°
5	Magnet : (1)space:No sensing (2)M : Sensing
6	(1)Spec.:JFS02(Refer to P14.3 order form) (2)T : 2 wires, 2 meters P : PNP3 wires, 2 meters N : NPN3 wires, 2 meters n : Q'ty



WS1 Swivel & Clamp Pneumatic Cylinders

External Dimensions

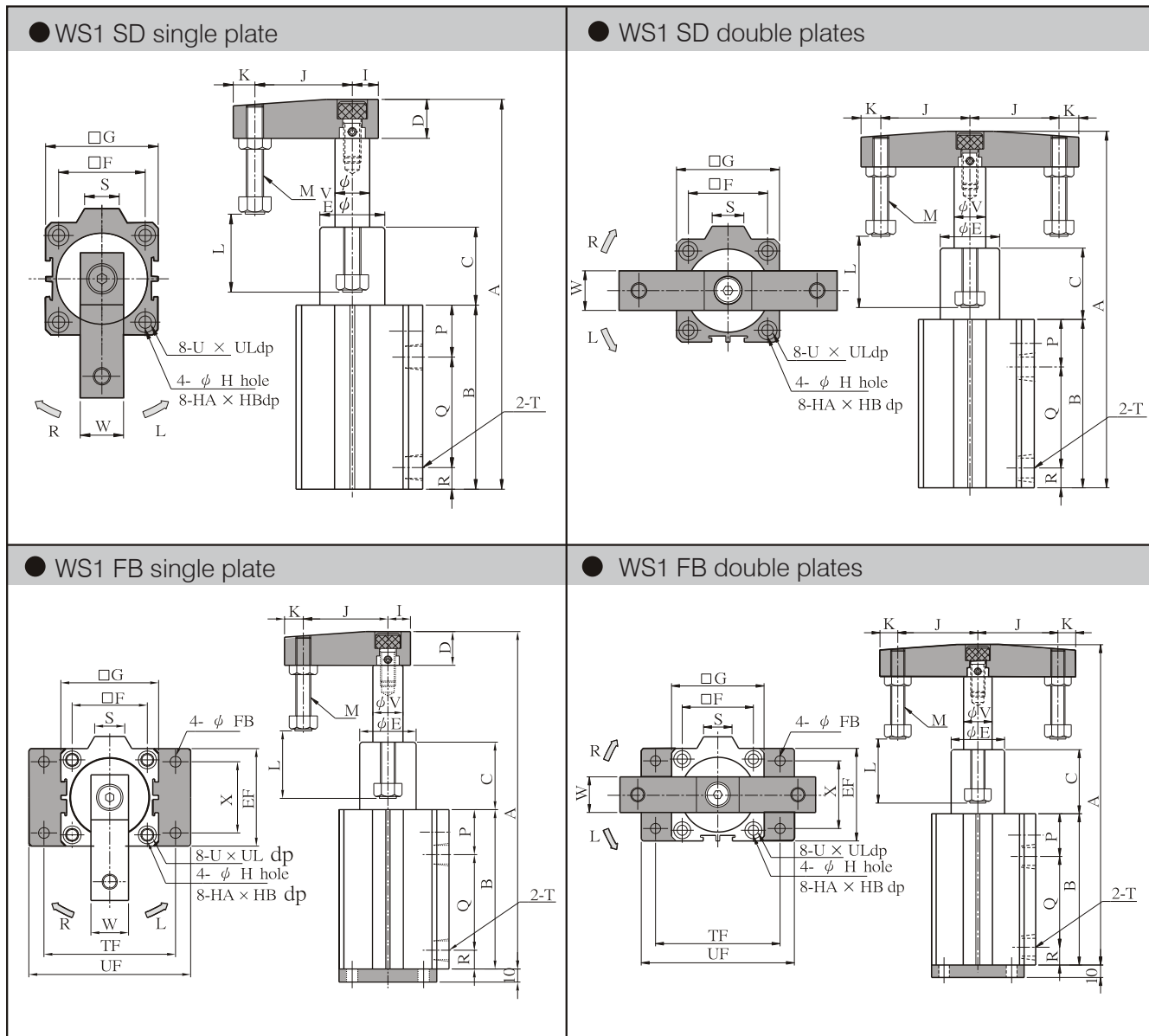

Item	A	B	C	D	E	F	G	H	HA	HB	I	J	K	L	M
Bore															
∅ 20	156	82	26	14	16	24	34	3.5	6	3.5	9	35	7	29.5	M6XP1.0
∅ 25	157	83	26	14	18	28	40	4.6	8	5.5	9	35	7	29.5	M6XP1.0
∅ 32	186,5	84	44	18	25	34	44	4.6	8	5.5	12	45	10	35	M8XP1.25
∅ 40	187	85	44	18	30	40	52	5.7	9.5	7.5	12	45	10	35	M8XP1.25
∅ 50	214,5	96,5	50	22	37	48	62	6.8	11	8.5	13	65	10	40	M10XP1.5
∅ 63	217	100	50	22	48	60	75	6.8	11	8.5	13	65	10	40	M10XP1.5

Item	P	Q	R	S	T	U	UL	V	W	X	TF	EF	UF	FB
Bore														
∅ 20	32	41.5	8.5	10	M5X0.8	M5XP0.8	7	10	16	24	46	36	58	4.5
∅ 25	31	43.5	8.5	10	M5X0.8	M6XP1.0	9	10	16	28	54	42	68	5.5
∅ 32	24	50	10	16	RC1/8"	M6XP1.0	9	12	18	34	58	48	72	5.5
∅ 40	24	51	10	16	RC1/8"	M8XP1.25	12	16	20	40	68	58	84	6.6
∅ 50	29.5	56	11	20	RC1/4"	M8XP1.25	12	20	22	40	82	66	102	9
∅ 63	30	58	12	20	RC1/4"	M8XP1.25	12	20	22	50	96	78	116	9