

WINMAN WGRA-100 Paralel Tutucu / WGRA-100 Parallel Gripper

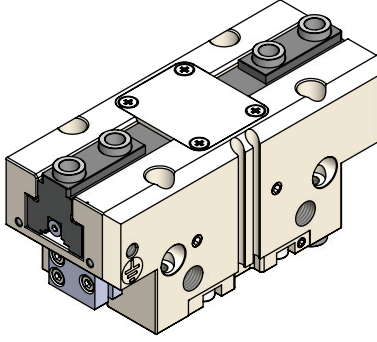

Özellikler / Specification

Ölçü / Size	100
Çalışma Tipi / Acting Type	Çift Etkili / Double Acting
Akışkan / Fluid	Hava (40µm filtrelenmiş) / Air (40µm filtered)
Çalışma Basıncı / Op. Pressure (min. -nom.-max.)	2,5 - 6 - 8 Bar
Sıcaklık / Temperature	0 ~ +80 °C
Manyetik / Magnetic	Standart / Standard
Açma Kuvveti / Opening Force	725 N
Kapama Kuvveti / Closing Force	660 N
Max. Ayak Bağlantı Yüğü / Max. Permissible Mass Per Finger	1,1 Kg
Max. Ayak Bağlantı Uzunluğu / Max. Permissible Finger Length	145 mm
Tek Çene Strok / Stroke per jaw	10 mm
Ağırlık / Weight	795 gr
Sensör / Sensor Switches	WT-07

Teknik Çizim / Technical Drawing

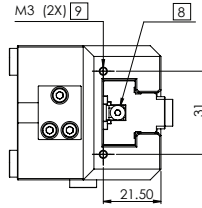
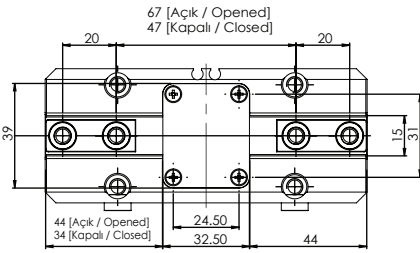

A-a	Gripper Açılır / Gripper Opening
B-b	Gripper Kapanır / Gripper Closing
1	Gripper Bağlantı / Gripper Connecting
2	Merkezeleme Burcu Bağlantı Deliği / Centering Bush Connection Hole
3	Parmak Bağlantısı / Finger Connection
4	Manyetik Sensör Kanalı (WT 07-...) / Magnetic Sensor Groove
5	Yakınlık Sensörü Tutucusu (Ø8) / Proximity Sensor Holder
6	Topraklama Bağlantısı / Ground Connection
7	Yağlama Deliği / Lubrication Hole
8	Yakınlık Sensör Ayar Vidası / Proximity Sensor Adjustment Screw
9	Bağlantı Deliği / Connection Hole

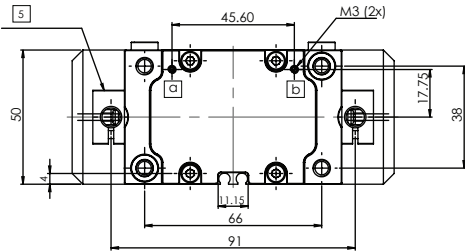
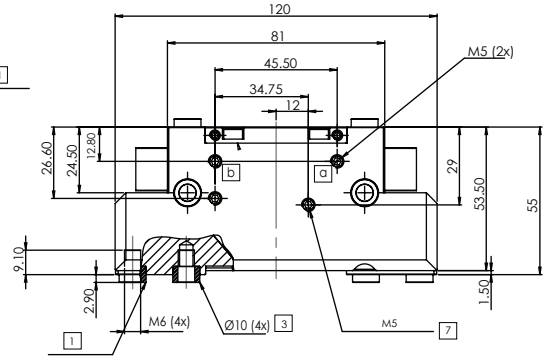
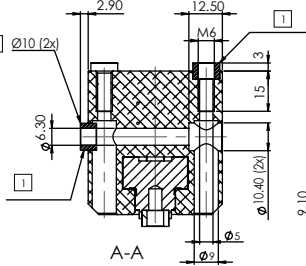
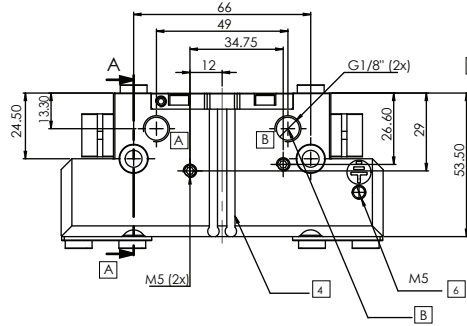

Sipariş Kodu / Ordering Code

MODEL MODEL	ÖLÇÜ SIZE
WGRA	100
PARALEL TUTUCU Parallel Grippers	SERİ Serial

WINMAN WGRA-100 Paralel Tutucu / WGRA-100 Parallel Gripper

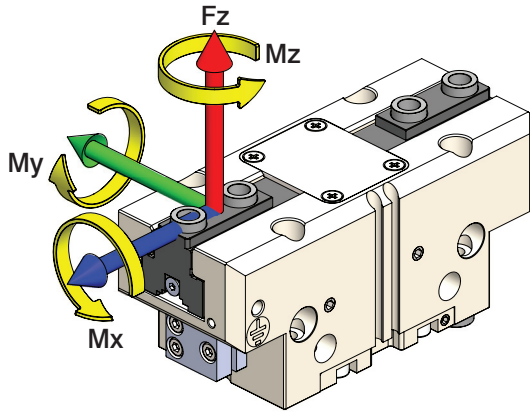

Özellikler / Specification

Mx	75 Nm
My	108 Nm
Mz	72 Nm
Fz	2030 Nm

Not: Belirtilmiş izin verilen torklar ve yukarıda verilen kuvvet birlikte meydana gelebilir, her bir tutucu çenesi için statik durumda geçerlidir. My torku, kavrama kuvveti tarafından üretilen torka ek olabilir.

The specified permissible torques and the force given below may occur together, apply in the static condition - per gripper jaw. The torque My may be in addition to the torque generated by the gripping force.

Tutucu Kuvvet Diyagramı / Gripping Force Diagram

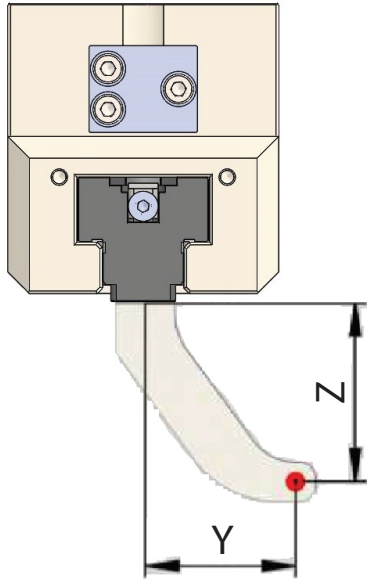

$$L_F = \sqrt{1,6 \cdot Y^2 + Z^2}$$

$$Y_{max} = \sqrt{\frac{L_{F\ max}^2 - Z^2}{1,6}}$$

$$Z_{max} = \sqrt{L_{F\ max}^2 - 1,6 \cdot Y^2}$$

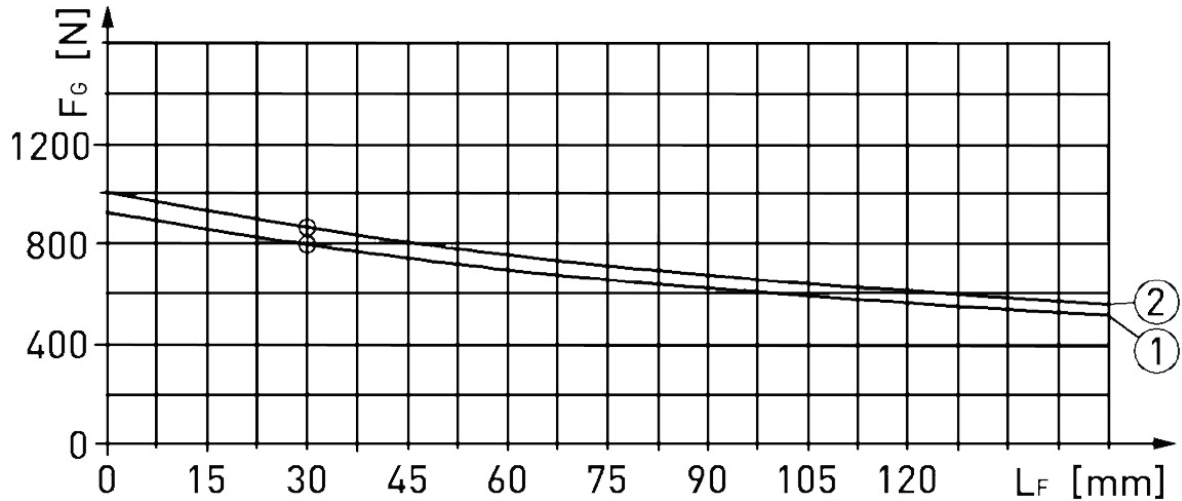

- ① WGRA - 100 Kapanma / Closing
- ② WGRA - 100 Açılma / Opening